

SHOP MATERIAL LIST FOR 1 S ASSEMBLY

MARK	SIZE	LENGTH MM	Total Qty.
RM1 - m1	ISMB150	2218	30
m2	ISMB150	460	30
m3	ISMB150	2086	30
p164	PLT8*200	200	30
p1407	PLATE8*60	150	150

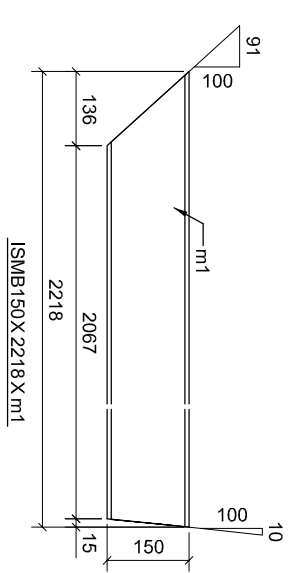

WELDING NOTATION

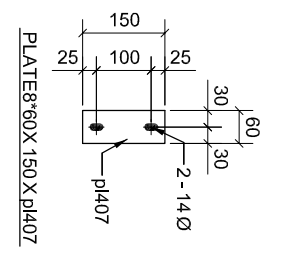
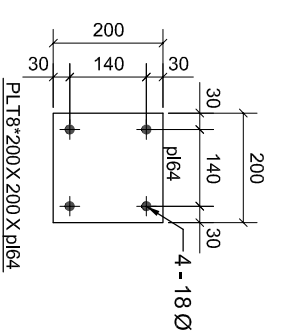
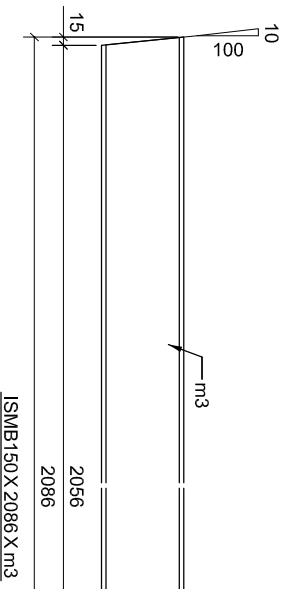
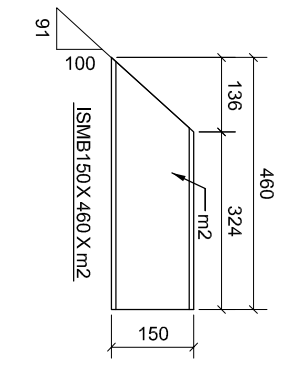
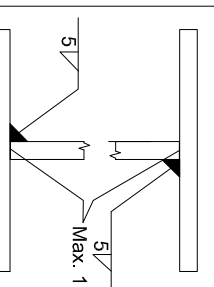

UNLESS NOTED OTHERWISE

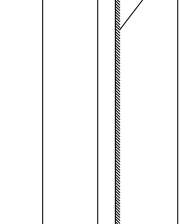

MATERIAL :-
QTY :- 15

NOTES:
UNLESS OTHERWISE SPECIFIED ALL DIMENSIONS ARE IN MM.
TOLERANCE FOR ALL ATTACHED COMPONENTS & C/D SHALL BE K 1mm.
TOLERANCE OVERALL LENGTH OF COLUMN & RAFTER K 2mm.

DATE	NAME	SCALE :
2011		
DRAWN		
CHKD		
APPD		
REV	MODIFICATIONS TECHNIQUES CONSTRUCT /MFR. TECHNICAL MODIFICATIONS	DATE
ITEM CODE :		
TITLE : NAVSAN GLASS LTD. ROOF MONITER		
DRG NO :	[RM.1]	REV. A
REF. DRG NO :		SHEET : 1 / 1

UNLESS SPECIFIED GENERAL TOLERANCE: IS - 1882 / 7215